

# Circuit Bodging

## Senseo Automisation

If you own a Senseo coffee machine you know how easy it is to operate this crafty little machine: Press the power button, wait for the water to boil and select either one or two cups. Although this is still less work than making “real” coffee, I would rather press just one button, let the machine power up by itself and pour me a cup when it’s done! So like the hobbyist I am, I decided to do something about it.

**Author:** Richard Bekking

There are two ways to make this work: The easy way - which involves de-soldering the micro controller and replacing it with a pin-compatible Atmel AVR; And the fun, semi analog way which I’m going to discuss in this issue of Circuit Boding.

### MODIFICATIONS

First of all you have to unplug and open up your precious coffeemaker to get to the internal circuitry (see the service manual on how to disassemble your Senseo: #1). Use figure 3 to locate the switch terminals, the LED terminal and the ground and supply terminals. Solder a wire to each of them and put the circuit board back. Run the wires nicely through the body and out the back behind the water reservoir for testing and hooking up our freshly build circuit later. Plug the Senseo back in and press the power button. When the LED stops flashing touch one of the switch wires with the ground wire. If there isn’t any water coming out you didn’t solder the wires correctly. You should also check if the voltage on the LED wire alternates between zero and three volts.

“THERE ARE TWO WAYS TO MAKE THIS WORK: THE EASY WAY, AND THE FUN, SEMI ANALOG WAY.”

### TRIPLE FIVE

The design is based on the famous 555 timer IC. The internal workings of this multifunctional integrated circuit are shown in figure 2. Most of the time this chip is wired as a bistable or astable circuit but we are only interested in the internal comparators. Notice that we can control the output of the 555 by

manipulating the voltages at the two comparators. The bottom comparator is associated with the TRIG terminal. If the signal supplied to this terminal drops below  $1/3$  of the supply voltage, the 555’s output goes high. If that signal rises past  $1/3$  of the supply voltage, nothing happens. The top comparator is connected with the REF terminal and resets the output of the 555 to zero

volts when the signal on this terminal exceeds  $2/3$  of the supply voltage. When that same signal drops below  $2/3$  of the supply voltage, again, nothing happens. So if we connect a single drive signal to both the TRIG and the REF input, we can manipulate the output of the 555 by making the drive signal drop below  $1/3$  or rise above  $2/3$  of the supply voltage.

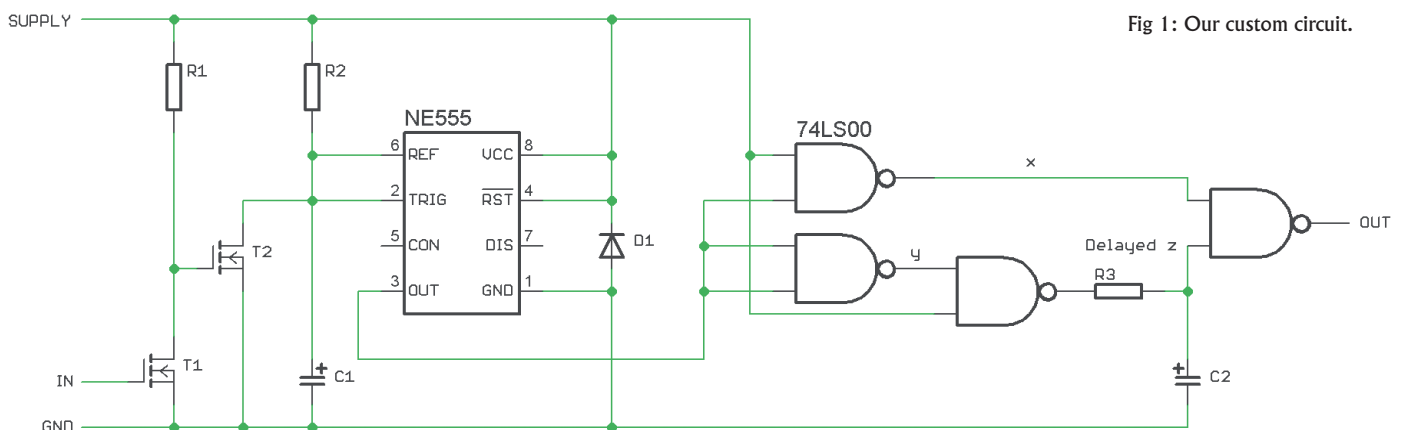

Fig 1: Our custom circuit.

#1 <http://www.eserviceinfo.com/download.php?fileid=19109>

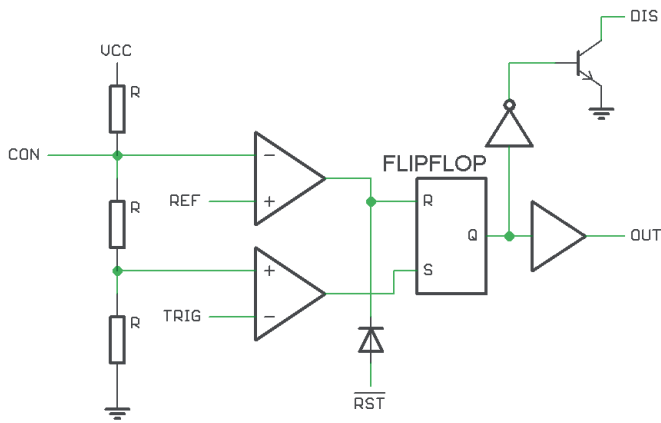

Fig 2: The internal workings of the NE555

## CHECKING THE LED

The circuit described here operates the Senseo basically the same way a human would. When the power button is pressed the circuit checks the blinking LED. When the blinking stops it “presses” either the one cup or two cup button. Consider the circuit in figure 1. The LED wire from the Senseo is attached to the gate of T1 which is an inverter that drives T2. When the LED is lit, T2 doesn’t conduct and C1 charges through R2. Because the voltage over C1 starts out as less than 1/3 of the supply voltage, the output of the 555 is high (this is our default or power up state). When the LED is dimmed, T2 will conduct and discharges C1 before it reaches 2/3 of the supply voltage and thus prevents it from resetting the output of the 555 to ground (see figure 2). If the LED stops blinking and remains lit, T2 will not conduct, giving C1 enough time to charge all the way up to the supply voltage, resetting the 555’s output as it goes. When the LED stops blinking the 555 will generate a single high to low transition which can be fed to one of the button wires. There is only one problem with this approach: If we directly connect this signal to one of the buttons, it appears to the Senseo that this button is pressed but never released! So we want to change the high to low transition into a high-low-high transition where the low state lasts about one second.

## PRESSING THE BUTTON

There is one very familiar situation in which a high to low transition of an input signal could result in a high-low-high response: a hazard in a combinatoric circuit! Typically we try to remove hazards from our digital circuits, but in this case we

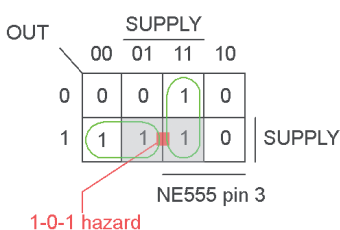

Fig 4: The K-map used.

are going to design one. It’s easy to design a circuit that implements a static 1-0-1 hazard with a Karnaugh map (K-map). In figure 4 you see the K-map for this particular circuit. In this

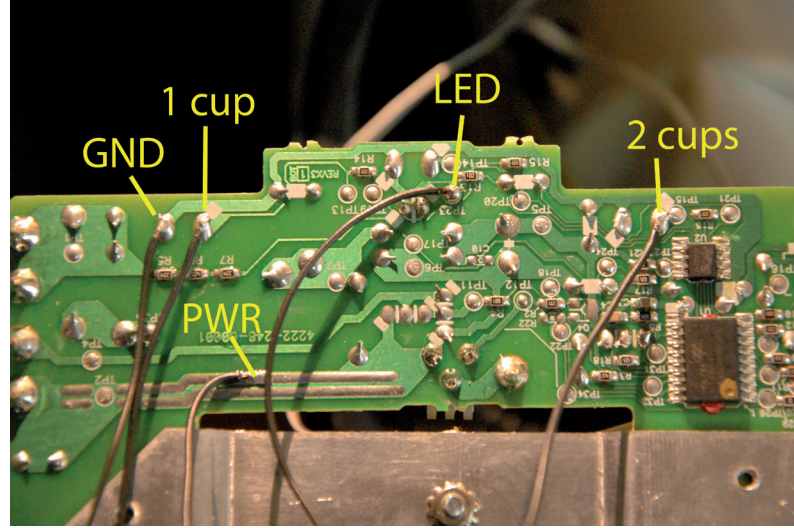

Fig 3: The solder points on the Senseo board.

K-map we placed the ‘1’s in a way that they cannot be grouped in one bounding box. We are forced to group the ‘1’s in two boxes next to each other instead. If there is no overlap between the groups there exists a situation where the output of the circuit temporarily jumps to an intermediate state (in this case that

## Part List

R1	10k
(R2, C1)	t = 3s
(R3, C2)	t = 1s
D1	1N4148
T1, T2	BS170
IC1	NE555
IC2	74LS00

happens when the output of the 555 changes from high to low, see figure 5). Because modern gates are very fast, this intermediate state only lasts for a few nanoseconds so we add an RC network to delay the voltage rise on the gate to a full second, long enough to simulate a button press.

## CONCLUSION

This circuit is a bit hacky but very easy to build and install without damaging the original circuitry of the Senseo. I designed and build this circuit last summer and it works like a charm although it’s still a bit of a work-in-progress. It would be a good idea to add a switch to choose which button to press (one cup or two cups). Adding a buzzer or a birthday card music circuit to the output of the circuit would give it a nice touch. Enjoy!

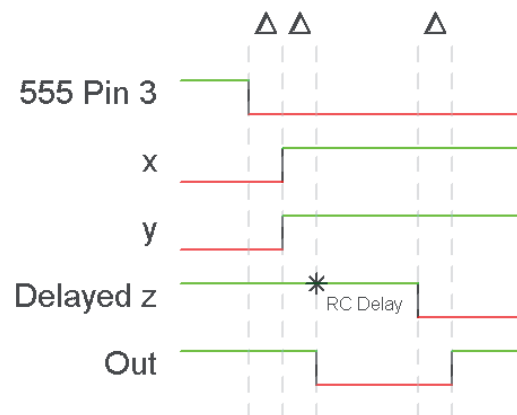

Fig 5: Signal timings.